

Welcome to tonight's City Council meeting!

The elected officials of the City of Bonners Ferry are appreciative of an involved constituency. Testimony from the public is encouraged concerning issues when addressed under the Public Hearing portion of the agenda. Any individual who wishes may address the council on any issue, whether on the agenda or not, during the Public Comments period. Normal business will preclude public participation during the business portion of the meeting with the discretion left to the Mayor and Council. Special accommodations to see, hear, or participate in the public meeting should be made at City Hall within two days of the public meeting.

Vision Statement

Bonners Ferry, "The Friendliest City", strives to achieve balanced growth, builds on community strengths, respects natural resources, promotes excellence in Government, and values quality of life. We are an inclusive city that welcomes all people, regardless of race, religion, color, national origin, sex, age, disability, sexual orientation, or gender identity and encourages their participation in city government and city programs.

AGENDA CITY COUNCIL MEETING Bonners Ferry City Hall 7232 Main Street 267-3105 May 19, 2020 6:00 pm

CONSENT AGENDA – {action item}

1. Call to Order/Roll Call
2. Approval of Bills and Payroll
3. Approval of the May 5, 2020 Council meeting minutes
4. Treasurer's Report

NEW BUSINESS

5. Electric – Consider Request to Advertise for the Electrical Vehicle Charging Station (attachment) {action item}
6. City – Consider Authorizing the Purchase of Refurbished Servers (attachment) {action item}
7. Street – Consider Authorizing the Purchase of a Jib Boom for Front End Loaders (attachment) {action item}
8. Water/Sewer – Consider Authorizing the Mayor to Sign Change Order #1 from Wink Inc for the Wilson – Solomon Corridor Project (attachment) {action item}
9. City – Discuss Health Insurance Options {action item}
10. City – Discuss Memorial Day Parade {action item}
11. City – Discuss the Fourth of July Celebration Activities (attachment) {action item}
12. Executive Session Pursuant to Idaho Code 74-206, Subsection 1 (d) To Consider Records that are Exempt from Disclosure as Provided in Chapter 1, Title 74, Idaho Code

ADJOURNMENT

"Pursuant to the Governor's Emergency Declaration regarding COVID-19 and accompanying Proclamation suspending the "in-person" attendance requirement of the Idaho Public Meetings laws, the City will be providing an electronic telecommunications method to allow the public to view the workshop remotely. Public attendance in person at the workshop will not be allowed in order to help prevent the potential spread of COVID-19. More details about this electronic viewing method is forthcoming."

INFORMATION

Letter from Marty and Teresa Becker

**MINUTES
CITY COUNCIL MEETING
Bonners Ferry City Hall
7232 Main Street
267-3105
May 5, 2020
6:00 pm**

Mayor Dick Staples called the Council meeting of May 5, 2020 to order at 6:00 pm. Present for the meeting were: Council President Rick Alonzo, Council Members Adam Arthur, Valerie Thompson and Ron Smith. Also present were: City Administrator Lisa Ailport, City Attorney Andrakay Pluid and City Clerk/Treasurer Christine McNair.

CONSENT AGENDA – {action item}

1. Call to Order/Roll Call
 2. Approval of Bills and Payroll
 3. Approval of the April 21, 2020 Council meeting minutes
- Adam Arthur moved to approve the consent agenda. Valerie Thompson seconded the motion. The motion passed. Adam Arthur – yes, Valerie Thompson – yes, Rick Alonzo – yes, Ron Smith - yes

NEW BUSINESS

4. City – Consider Approval of Ordinance # 593 and the Publication Summary Prohibiting Public Urination and Defecation and Have the First Reading by Title Only(attachment) {action item}
Andrakay said there have been a few incidents over the last few months. There is not an Idaho Code that specifically applies to this. After discussion with the Police Department, this is the solution that was developed. Rick Alonzo moved to approve Ordinance #593 and the publication summary prohibiting public urination and defecation and have the first reading by title only. Adam Arthur seconded the motion. The motion passed. Adam Arthur – yes, Valerie Thompson – yes, Rick Alonzo – yes, Ron Smith – yes. Andrakay read the ordinance by title only.
5. City – Suspend the Reading Rules and Adopt Ordinance # 593 {action item}
Adam Arthur moved to suspend the reading rules and adopt Ordinance # 593. Valerie Thompson seconded the motion. The motion passed. Adam Arthur – yes, Valerie Thompson – yes, Rick Alonzo – yes, Ron Smith – yes
6. Electric – Consider Authorizing the Mayor to Sign the Contract with CDA Stump Grinding for Tree Removal Services (attachment) {action item}
Mayor Staples asked about the contract that we have with CDA Stump Grinding. Lisa said this contract is for certain trees that require. Ron asked if the trees are on private property. Lisa said yes, but these trees are a risk to the City's infrastructure. Valerie Thompson moved to authorize the Mayor to sign the contract with CDA Stump Grinding for tree removal services, in an amount not to exceed \$9,300. Rick Alonzo seconded the motion. The motion passed. Adam Arthur – yes, Valerie Thompson – yes, Rick Alonzo – yes Ron Smith – yes
7. Water/Sewer – Consider Pay Application #1 from Wink Inc for the Wilson – Solomon Corridor Project (attachment) {action item}
Ron asked what this will look like when it is completed. Lisa said it will only be a base layer/gravel road. The developer will be required to complete the road. Valerie asked about increased costs due to the items found while excavating. Andrakay said that will come forward as a change order. Ron Smith moved to approve pay application #1 from Wink Inc in the amount of \$27,803.36 for the Wilson – Solomon Corridor Project. Adam Arthur seconded the motion. The motion passed. Adam Arthur – yes, Valerie Thompson – yes, Rick Alonzo – yes, Ron Smith – yes
8. Pool – Discuss Wage Scale for the Lifeguards (attachment) {action item}
Lisa said this is only for the head lifeguard. She is requesting adding a pay designation for a head lifeguard without the water safety instructor (WSI) certification. Rick Alonzo moved to adopt the wage scale for the head lifeguard. Adam Arthur seconded the motion. The motion passed. Adam Arthur – yes, Valerie Thompson – yes, Rick Alonzo – yes, Ron Smith – yes

9. City – Consider Re-Opening Date and Requirements for City Hall {action item}

Christine said City Hall was re-opened today. Mayor Staples said there had been discussion about when to re-open City Hall. Adam asked if it is necessary to have City Hall open long term. Adam said most things can be done over the internet and people can make appointments if necessary. Rick said he feels it is good for people to be able to access City Hall.

10. Executive Session Pursuant to Idaho Code 74-206, Subsection 1 (f) to communicate with legal counsel for the public agency to discuss the legal ramifications of and legal options for pending litigation, or controversies not yet being litigated but imminently likely to be litigated. The mere presence of legal counsel at an executive session does not satisfy this requirement

Rick moved to enter into executive session pursuant to Idaho Code 74-206, subsection 1 (f) to communicate with legal counsel for the public agency to discuss the legal ramifications of and legal options for pending litigation, or controversies not yet being litigated but imminently likely to be litigated. The mere presence of legal counsel at an executive session does not satisfy this requirement. Valerie Thompson seconded the motion. The motion passed. Adam Arthur – yes, Valerie Thompson – yes, Rick Alonzo – yes, Ron Smith – yes

Entered executive session at 6:36 pm

Executive session ended at 7:25 pm with no action taken.

ADJOURNMENT

The meeting adjourned at 7:25 pm.

“Pursuant to the Governor’s Emergency Declaration regarding COVID-19 and accompanying Proclamation suspending the “in-person” attendance requirement of the Idaho Public Meetings laws, the City will be providing an electronic telecommunications method to allow the public to view the workshop remotely. Public attendance in person at the workshop will not be allowed in order to help prevent the potential spread of COVID-19. More details about this electronic viewing method is forthcoming.”

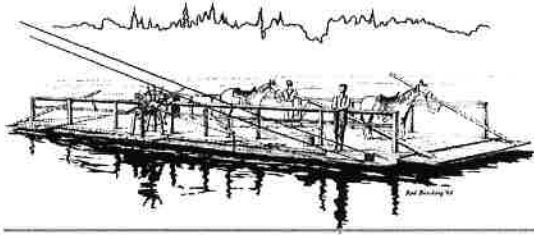

CITY OF BONNERS FERRY

7232 Main Street
P.O. Box 149
Bonners Ferry, Idaho 83805
Phone: 208-267-3105 Fax: 208-267-4375

TO: Mayor and City Council

FROM: Lisa Ailport, City Administrator *LMA*

DATE: May 13, 2020

RE: Request to seek bids for Electrical Vehicle Charging Station

The attached bid documents for the purchase of the electrical vehicle charging station are before you for approval. The anticipated total costs of this unit exceeds \$50,000.00 and therefore we are required under the Idaho Procurement laws to seek three informal bids. The attached bid docs set forth the expectation of what we would accept for a bid.

All of the costs of the unit would be reimbursed through the Department of Environmental Quality, EVCS grant that we received back in January. The initial cost would be paid through the electric department and then reimbursed through the program grant dollars.

Please let me know if you have any questions.

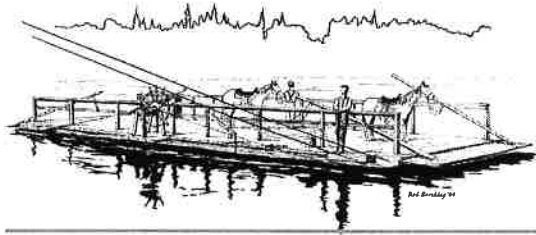

CITY OF BONNERS FERRY

7232 Main Street
P.O. Box 149
Bonners Ferry, Idaho 83805
Phone: 208-267-3105 Fax: 208-267-4375

May 5, 2020

Subject: City of Bonners Ferry – 2020 Electric Vehicle Charging Station System Procurement

The City of Bonners Ferry is requesting bids to purchase a DC single-port fast charger station at our downtown city lot near our city visitor's center, as described in the Project Specifications titled Electric Vehicle Charging Station System Procurement.

Responses to this request for bids are per Idaho Code 67-2805 (1). If you desire to provide a bid for this project, your written bid shall be delivered to City Hall on the attached form by no later than **12:00 pm (noon) Friday May 29, 2020** or provided to the City Administrator by email by the time and date stated.

The City reserves the right to reject any and all quotes and accept the quote it deems most advantageous and to waive formalities.

If you have any questions, feel free to email at lailport@bonnersferry.id.gov or call me at (208) 267-4379.

Sincerely,

Lisa Ailport
City Administrator

2020 DC Fast Charger - Bid Form

Item	Minimum Specifications	Bid Amount
DC Single Port Fast Charger	DC Station (US version), 2x power Modules, 1x CCS1 cable, 1x CHAdeMO cable and software upgrade to increase max power from 50 kW to 62.5 kW.	
Warranty	5-year comprehensive parts and on-site labor warranty plan. Includes station management, remote monitoring of station and proactive repair dispatch.	
Commercial Cloud Plan	5-year DC, Commercial Cloud Plan. Including Secure Network Connection, On-going Station Software updates, 24x7 Driver Support, Host Support, Session Data and Analytics, Driver Access Control, Pricing and Automatic Funds Collection, Waitlist.	
Shipping/Delivery Cost	All costs associated with receiving the unit to the city yard in Bonners Ferry, Idaho.	
Installation Cost/Kits	Any specific installation products or kits supplied by the contractor required to properly install the unit	
Start-Up Costs	Initial testing and start-up services	
Total		

Understanding that this lump sum price and per unit prices includes all permit fees, sales and consumer use taxes, etc. required by law or regulation.

Signed _____

Name and Title _____

Date _____

Company Name _____

Company Address _____

Phone Number _____

Email: _____

ELECTRIC VEHICLE CHARGING STATION SYSTEM
PROCUREMENT DOCUMENT

PART 1 - GENERAL

1.1 Contract Documents: Below is the list of items considered the contract documents for this procurement.

- A. The Request for Bids
- B. Charge Point Information Packet
- C. The Bid Form.
- D. Sample - City of Bonners Ferry Contract
- E. Performance Bond
- F. Payment Bond, if applicable
- G. This specification titled *Electric Vehicle Charging Station System Procurement*

1.2 SUMMARY

- A. It is the intent of this Specification to describe and procure an electric vehicle charging station system that consists of the minimum specs of a Charge Point Express 250 DC Station, and must include the following components:
 - 1. DC Station unit
 - 2. 2x Power Modules, including one CCS1 cable and one CHAdeMO cable
 - 3. Software upgrade to increase max power from 50kW to 62.5kW
 - 4. 5-year comprehensive parts and on-site labor warranty plan. Includes station management, remote monitoring of station and proactive repair dispatch
 - 5. 5-year DC, Commercial Cloud Plan. Including Secure Network Connection, On-going Station Software updates 24x7 Driver Support, Host Support, Session Data and Analytics, Driver Access Control, Pricing and Automatic Funds Collection, Waitlist.
 - 6. Any specific installation products or kits supplied by the contractor required to properly install the unit.
 - 7. Any initial testing, special inspections and start-up services.
- B. This Specification describes the electric vehicle charging station system as illustrated by the information provided and attached. Should the requirements of this specification contradict any other section of the project specifications, this section shall govern.
- C. Other Terms:

Contractor: for the purposes of this document, the term Contractor means the supplier.

Owner: for the purposes of this document, the terms City and Owner refer to the City of Bonners Ferry. The City Engineer or City Administrator will function as the representative for the City of Bonners Ferry.

1.3 SYSTEM PERFORMANCE REQUIREMENTS

- A. System Description: The system description is based on a Charge Point Express 250 DC Station. Those specifications are attached hereto.

1.4 SUBSTITUTIONS

- A. *Substitutions or alternates to the specified products in this document are allowed, but must meet the material and dimensional characteristics of the specified product.* A supplier providing an alternate to the Charge Point Express 250 DC Station must provide specifications for the alternate that show dimensionally and materially, that the alternate is the same as that found in this document.

1.5 QUALITY ASSURANCE

- A. Warranty: The product shall be guaranteed by the contractor/supplier performance for a period of five (5) years.
- B. Contractor will provide start up services.

1.6 EXTRA MATERIALS

- A. The contractor shall furnish all required materials for the installation of the DC station. The owner shall be responsible for any make ready work, including preparing proper power to the site and an area for the unit to be placed.
- B. The owner shall also be responsible for installing the unit; the contractor shall be there to provide start up services and to ensure proper installation and set up.

1.7 DELIVERY AND HANDLING:

- A. All cost for the unit shall include shipping/delivery and handling. The owner is not responsible for any costs associated with delivery and handling not bid.

1.8 PROJECT SITE CONDITIONS:

- A. The project site is an existing paved parking lot.

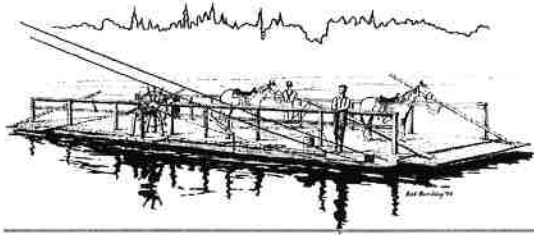

CITY OF BONNERS FERRY

7232 Main Street
P.O. Box 149
Bonners Ferry, Idaho 83805
Phone: 208-267-3105 Fax: 208-267-4375

TO: Mayor and City Council

FROM: Lisa Ailport, City Administrator *LMA*

DATE: May 13, 2020

RE: **Request to purchase refurbished servers**

Brian Errett- our IT Manager has begun to plan for phasing out our older, outdated server with newer models that can support the city's IT needs. Brian has proposed to purchase three refurbished servers at a greatly reduced cost to a new sever but needs to be fast and nimble in order to get these when they come up for sale (see correspondence below).

"...our virtual machine host is quite old and also limited in performance. Most of the windows servers on it are under-allocated even according to Microsoft's specifications. We also do not have any warranty support on the hardware or redundancy so if we have a failure we would be down until parts could be ordered in. I would like to suggest purchasing 2-3 servers to replace what we have - if we go with "refurbished" systems we can save a lot [of] the cost [of a new server]. I am comfortable repairing these at any level and so if we get 3 where we need 2 we would have parts on hand for most any failure. Even purchasing 3 would be less than new systems. I'll give you an example.

3 refurbished R820 32 core 256GB RAM - \$1130.00 x3 = \$3390.00

1 new R840 32 core 256GB RAM - \$19,000

The refurbished systems are somewhat of a moving target as they are available in limited quantities and configurations. I am familiar with the component sets enough to pick the right configurations that would work for us - But when I find a set of matching ones we would want to move quickly on the purchase. More come available all the time but in order to get matching sets of components to have the ability to swap parts it would be better to get them at the same time. I can find the components separately but they are more expensive that way."

Based on the above, it is my recommendation that Council authorize staff to purchase refurbished servers to replace our existing server and to authorize up to \$8,000.00 to complete this task.

Please let me know if you have any questions.

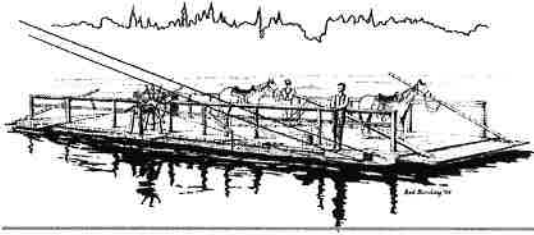

CITY OF BONNERS FERRY

7232 Main Street
P.O. Box 149
Bonners Ferry, Idaho 83805
Phone: 208-267-3105 Fax: 208-267-4375

TO: Mayor and City Council

FROM: Lisa Ailport, City Administrator *LMA*

DATE: May 13, 2020

RE: Request to purchase boom lift for Street Department front end loader

The Street Department is asking for approval to purchase a Jib Boom lift for the front end loader that the streets department owns. Mr. Youngwirth, the Street Superintendent, has provided Council a short memo on the purpose of the request as well as information on the Jib Boom (see attachment).

Given the cost of oil it appears we predict that we will save money on chip sealing and asphalt this year. The Streets Department budgeted \$107,409.00 for both these expenses and expects to do less this year as well as the costs of product being much less than initially budgeted.

With this in mind, we can use a portion of the chip sealing and asphalt budget to cover the cost of the jib boom at a cost of approximately \$4,200.00.

It is my recommendation that council authorize the Street's department to purchase the jib boom for \$4,200.00 and to make adjustments in the chip sealing and asphalt budget to accommodate this purchase.

Please let me know if you have any questions.

Request of City Council to allow the Street Dept. to purchase a Jib boom with quick coupler for our front end loaders.

The Street Dept. needs to purchase a quick connect jib boom that will allow us to load and move heavy bulky things while helping keeping our staff safe from being crushed and smashing body parts.

Currently we are using a chain and the loader bucket to load and unload our sander boxes into the dump trucks in the fall and also in the spring to unload the boxes and load the oil tanks or anything else that is heavy and bulky. When we try to load big things the loader bucket does not have the reach we need to set things safely into a truck dump box. Also it is very dangerous for us to set our concrete storm sewer boxes with our excavator because it barely has the lifting capacity for these concrete storm boxes and the loader with just a bucket does not have the reach to get close enough to the hole to set the box.

For all the years I have worked here we have talked about buying one of these and making it safer for our crew but once you just do it and move on and forget about it.

I now am not forgetting about it! We need this piece of equipment before someone dose get seriously hurt.

Thanks for your consideration.

Attached is some more information, and a quote.

John Youngwirth and the City Street Crew

If you have any questions feel free to call me. 208-290-2220

MACHINERY
Quote Summary

Prepared For:
 CITY OF BONNERS FERRY
 Po Box 149
 Bonners Ferry, ID 83805
 Business: 208-267-3105
 johnny@bonnersferry.id.gov

Prepared By:
 JASON JONES
 Pape Machinery, Inc.
 W 6210 Rowand Road
 Spokane, WA 99224
 Phone: 509-838-5252
 Mobile: 509-671-0449
 jjones@papemachinery.com

Quote Id: 21669873
Created On: 21 April 2020
Last Modified On: 21 April 2020
Expiration Date: 28 April 2020

Equipment Summary	Selling Price	Qty	Extended
PALADIN Jib Boom	\$ 4,123.89 X	1 =	\$ 4,123.89
Equipment Total			\$ 4,123.89

Quote Summary	
Equipment Total	\$ 4,123.89
Federal Excise Tax	\$ 0.00
Licensing Fee	\$ 0.00
CA Tire Recycling Fee	\$ 0.00
Doc Fee	\$ 0.00
Rental Services Fee	\$ 0.00
SubTotal	\$ 4,123.89
Total	\$ 4,123.89
Down Payment	(0.00)
Rental Applied	(0.00)
Balance Due	\$ 4,123.89

Salesperson : X _____

Accepted By : X _____

Selling Equipment



Quote Id: 21669873

Customer: CITY OF BONNERS FERRY

PALADIN Jib Boom

Hours: 0

Stock Number:

Code	Description	Qty
90T0037	3 section jib boom for 544 loader	1



OPERATOR'S MANUAL

EXTENDABLE & STINGER BOOMS

FOR
LOADERS

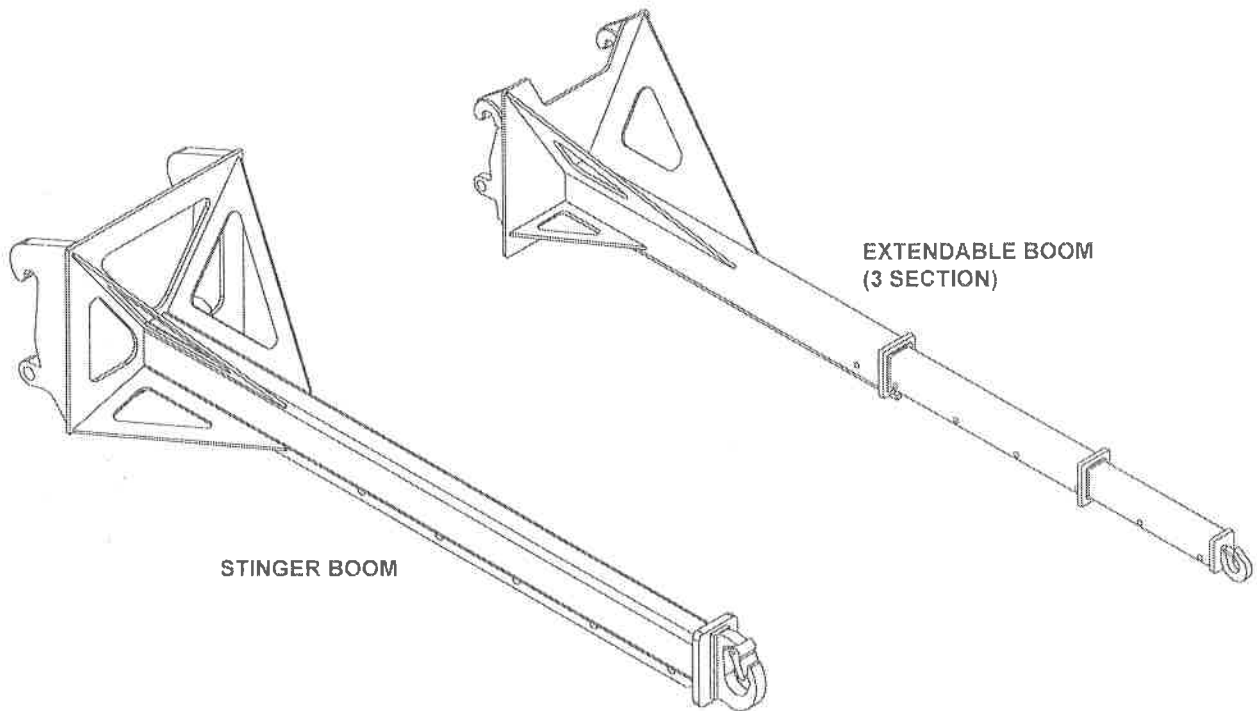

SERIAL NUMBER: _____

MODEL NUMBER: _____

Manual Number: OM90T
Date: August 2018
Rev.

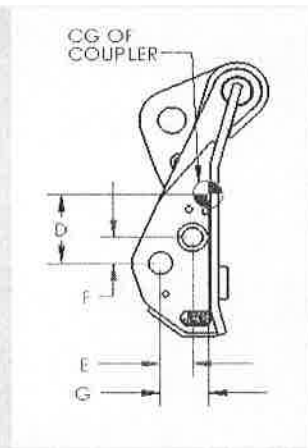
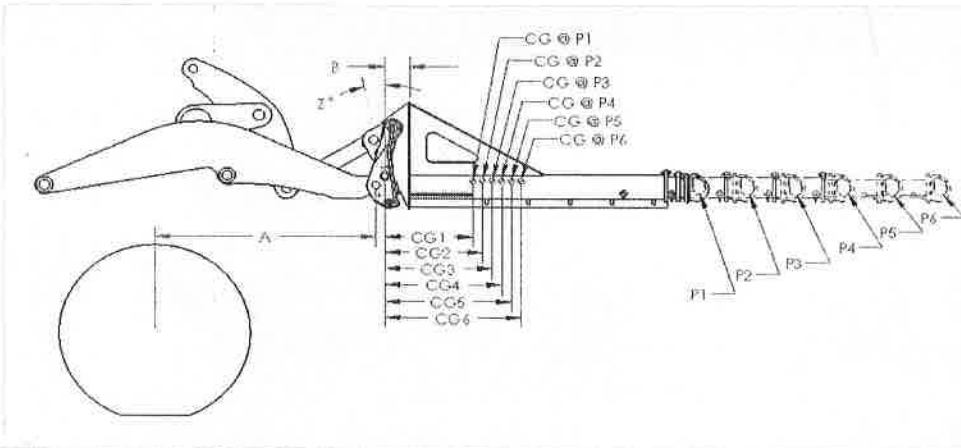

ALLOWABLE LIFT LOAD CHART FOR JD 544K

OEM TIPPING LOAD- STRAIGHT (W/ BUCKET)	24,021 lbs
OEM TIPPING LOAD- FULL TURN (W/ BUCKET)	20,799 lbs
OEM BUCKET WEIGHT (BUCKET USED WITH ABOVE TIPPING)	2,305 lbs

JRB BOOM NUMBER	90T0037
WEIGHT OF ATTACHMENT	1196.52 lbs
A (CENTER OF TIRE TO PIN)	70.07"
B (PIN TO FRONT OF MAIN PLATE)	9.81"
Z* (DEGREES ROTATED FROM STANDARD)	7.30 deg

JRB COUPLER NUMBER	92F0004
WEIGHT OF COUPLER	713.07 lbs
B (PIN TO CG OF COUPLER)	7.17"
G (PIN TO CG OF COUPLER)	4.68"
E (PIN TO PLUNGER HOLE)	3.15"
F (PIN TO PLUNGER HOLE)	2.77"

	CG1	CG2	CG3	CG4	CG5	CG6
CG# (PIN TO CG# OF BOOM)	32.23	40.07	43.95	47.82	49.32	53.52

P DIMENSIONS ARE FROM FRONT PLATE OF BOOM TO LOAD POSITION P1@89.75" P2@104.75" P3@119.75" P4@134.75" P5@149.75" P6@164.75"

	@P1	@P2	@P3	@P4	@P5	@P6	
W/ JRB BOOM TIPPING LOAD: STRAIGHT	9553.03	8746.54	8081.66	7507.79	7019.50	6577.01	lbs
W/ JRB BOOM TIPPING LOAD: FULL TURN	8271.65	7573.34	6997.65	6500.75	6077.96	5694.82	lbs
SAE ALLOWABLE LOAD	4135.83	3786.67	3498.82	3250.38	3038.98	2847.41	lbs

Don K
1/31/2012

* DIMENSION IS A CLOSE APPROXIMATION



MEMO

CITY OF BONNERS FERRY
CITY ENGINEER

Date: May 15, 2020
To: City Council
From: Mike Klaus, City Engineer
Subject: Water & Sewer Departments - Wilson-Solomon Utility Corridor Pay Change Order #1

During construction of the water and sewer mains for the Wilson-Solomon project, the contractor encountered approximately 300 cubic yards of buried metals in the construction path. It would have been very difficult to complete construction of the water and sewer mains without removing all of the foreign material.

Additionally, I believe that unusual settling would occur later in the future roadway, with the metal left in place. The City requested a change order cost from the contractor for removing the metal and replacing it with fill material that will provide a good road bed as well as support the buried utilities.

Wink Inc. provided two costs for the change order; one included Wink hauling the material away and the other included the City hauling it away. The street department hauled the material away and reduced the change order cost by about \$3,000. I do recommend approval and payment of Change Order #1 that includes \$6,075 in additional project cost as well as one additional contract day. The cost and additional time is shown in the attached documentation.

Please let me know if you have any questions.

Thank you,

Mike

Change Order No. 1

Date of Issuance: 4/30/2020

Effective Date: 4/30/2020

Project: <u>Wilson to Solomon Utility Corridor Project</u>	Owner: <u>City of Bonners Ferry</u>	Owner's Contract No.:
Contract:		Date of Contract: <u>March 26, 2020</u>
Contractor: <u>Wink, Inc.</u>		Engineer's Project No.: <u>51009.002.01</u>

The Contract Documents are modified as follows upon execution of this Change Order:

Description:

Misc. metal debris was found within the trench line during the installation of the sewer near STA 8+00. The buried material limits were identified within the right-of-way, excavated, stockpiled and replaced with structural import.

Attachments (list documents supporting change):

Contractor's estimate for excavation, structural import and loading City trucks per estimated volumes of material.

CHANGE IN CONTRACT PRICE:

CHANGE IN CONTRACT TIMES:

Original Contract Price:

\$358,690.00

[Increase] [~~Decrease~~] from previously approved Change Orders No. 0 to No. 0:

\$0.00

Contract Price prior to this Change Order:

\$358,690.00

[Increase] [~~Decrease~~] of this Change Order:

\$6,075.00

Contract Price incorporating this Change

\$364,765.00

Original Contract Times: Working days Calendar days

Substantial completion (days or date): 60

Ready for final payment (days or date): 70

[Increase] [~~Decrease~~] from previously approved Change Orders No. 0 to No. 0:

Substantial completion (days): 0

Ready for final payment (days): 0

Contract Times prior to this Change Order:

Substantial completion (days or date): 60

Ready for final payment (days or date): 70

[Increase] [~~Decrease~~] of this Change Order:

Substantial completion (days or date): 1

Ready for final payment (days or date): 1

Contract Times with all approved Change Orders:

Substantial completion (days or date): 61

Ready for final payment (days or date): 71

RECOMMENDED:

By: *Ryan J. Luttmann PE*
Engineer (Authorized

Name: RYAN J. LUTTMANN
Print Name

Date: 5/12/2020

Approved by Funding Agency (if applicable):

ACCEPTED:

By: _____
Owner (Authorized

Name: _____
Print Name

Date: _____

ACCEPTED:

By: *Cathy Winkler Sec.*
Contractor (Authorized

Name: _____
Print Name

Date: 5-15-2020

Date: _____

CHANGE ORDER 1 ESTIMATE

WINK INC.

Crushing. Hauling. Excavating.
Bonners Ferry, ID 208-267-5804

To: Century West Engineering	Contact: Ryan Luttmann
Address:	Phone:
	Fax:
Project Name: Wilson to Solomon Utility Corridor	Bid Number:
Project Location:	Bid Date: 4/30/2020

We are pleased to submit the following estimate:

Item Description	Estimated Quantity	Unit	Unit Price	Total Price
1. Change Order 1 - CITY HAUL OFF				
Excavate and Stockpile Garbage	300	CY	\$4.00	\$1,200.00
Structural Import (Placed & Compacted)	250	CY	\$18.00	\$4,500.00
Load City Trucks	300	CY	\$1.25	\$375.00
Total Price for 1. Change Order 1 Bid Items:				\$6,075.00

Item Description	Estimated Quantity	Unit	Unit Price	Total Price
2. Change Order 1 - WINK HAUL OFF				
Excavate and Stockpile Garbage	300	CY	\$4.00	\$1,200.00
Structural Import (Placed & Compacted)	250	CY	\$18.00	\$4,500.00
Disposal (If location is Landfill or Lagoon)	300	CY	\$12.00	\$3,600.00
Total Price for 2. Change Order 1 Bid Items:				\$9,300.00

Notes:

- DISPOSAL DOES NOT INCLUDE LANDFILL FEE.
- Disposal costs will increase if location is further than the proposed locations
- Pricing includes all taxes
- State of Idaho Public Works: 016872-AA-1-4
Construction Contracting Business: RCE-4551



Bonnerr's Ferry July Fourth



Honorable Mayor Staples and Bonners Ferry City Counsel

May 14, 2020

Dear Friends,

My name is Gary Leonard. We are in the unchartered territory of our nation's history. With all the fear and isolation, it seems impossible to even think about planning our community's July Fourth Celebration. With unemployment soaring and most local businesses deemed non-essential, I think you agree we are all suffering a bit, many more than others. So, how can I even talk about this?

Here is my answer, I have faith that we will be able to gather, as a community, by July Fourth and therefore, I am moving forward. What better time to bring our community together after these events than to have a parade, picnic, games, entertainment, and fireworks. [or as Alan says "blow stuff up"]

In keeping with tradition, we are still planning an "Old Fashioned, All American, Small Town Celebration". As long as I am involved, I will ensure we will have a classic family-oriented Boundary County celebration. We are actively planning and have ordered the fireworks.

It is a pretty weird time, but I know, by July Fourth, we will be ready to assemble and reconnect with our neighbors. We will have an historic July Fourth Celebration [in a positive way].

I am submitting my Special Event Permit Application today with this letter and ask you to approve this event at as soon as feasible.

There is something else to consider. I have received unconfirmed reports that Sandpoint, Troy, and Libby are all cancelling their July Fourth events. I do not promote our event for other cities or states but I am sure there are those that may want to attend resulting in an increased burden on local resources.

Thank you so much for your support...

Sincerely,

Gary Leonard

RECEIVED

MAY 14 2020

CITY OF BONNERS FERRY



CITY OF BONNERS FERRY SPECIAL EVENT PERMIT APPLICATION

NAME OF EVENT: Bonnerr Ferry July 4

DATE OF EVENT: July 4, 2020

TIME OF EVENT: Start: 5:30 P End: 10:45P

LOCATION OF EVENT (include street names, property names, etc.): City for parade
fairgrounds for picnic, Games, fireworks

NUMBER OF PEOPLE IN ATTENDANCE: 300-1200

WILL EVENT OCCUPY OR REQUIRE CLOSURE OF A PUBLIC STREET: Yes: No:
If yes, please attach diagram of proposed closures.

WILL ALCOHOL BE SERVED: Yes: No:

IF YES, HAS CATERING PERMIT BEEN SECURED: Yes: No:

DESCRIPTION OF EVENT: July Fourth parade, picnic, fun,
entertainment, and fireworks

DESCRIPTION OF EXTRA POLICE OR FIRE PROTECTION NEEDED: As needed
for crowd & fire control

NAME OF APPLICANT/ORGANIZATION: Bonnerr Ferry July Fourth

ADDRESS: PO Box 1714 Bonners Ferry ID 83805

PHONE NUMBER: 208 946 9579

NAME OF PRIMARY CONTACT PERSON: Gary Leonard

PHONE NUMBER: 208 946 9579

EMAIL: gary@july-fourth.us

RECEIVED
MAY 13 2020

PLEASE ATTACH OR SUBMIT THE FOLLOWING ITEMS WITH APPLICATION:

- Proof of a comprehensive general liability insurance policy in the amount of one million dollars (\$1,000,000), naming the City of Bonners Ferry as a co-insured party.
- Permit fee and clean up fee as set by resolution of the City Council.

CITY OF BONNERS FERRY
RECEIVED
MAY 14 2020
CITY OF BONNERS FERRY

****SPECIFIC RULES FOR PARADE APPLICANTS****

- No throwing candy or items from other vehicles (must hand out)
- No sirens during parade
- No debris left on streets. If animals are to be part of the parade, there must be someone designated to follow behind and clean up after the animals.

INDEMNIFICATION AND HOLD HARMLESS AGREEMENT

By this application, the applicant shall, waive, indemnify, and hold harmless the City of Bonners Ferry, its agents, its employees and authorized volunteers from and against all claims, damages, losses and expenses, including attorneys' fees, arising out of the permitted activity or the conduct of applicant's operation of the event if such claim (1) is attributed to personal injury, bodily injury, disease or death, or to injury or to destruction of property, including the loss of use there from, and (2) is not caused by any gross negligent act or omission or willful misconduct of the City of Bonners Ferry or its employees acting within the scope of their employment.

Signature of Applicant: 

Printed Name: Gary Leonard

Office/Title: Owner/Manager

Date: 5-13-20

Clerk's Office Use:

Fee Paid _____ Date _____ Receipt No. _____

Chief of Police _____ Date _____

Fire Chief _____ Date _____

ARIZONA STREET

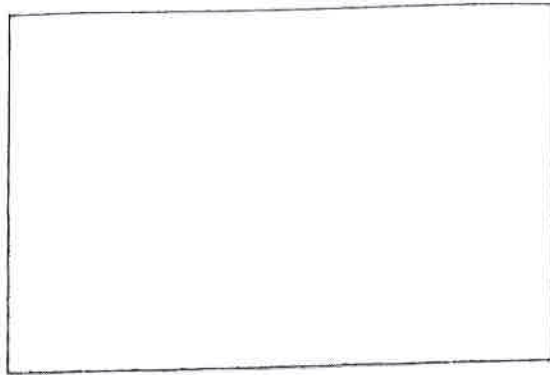
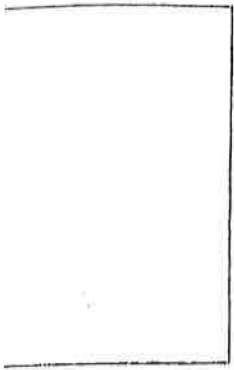

KOOTENAI STREET

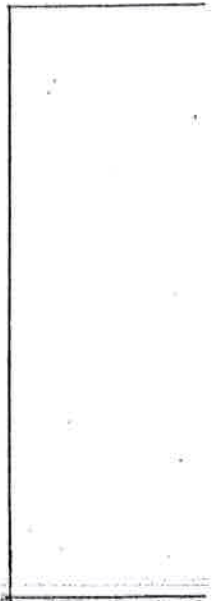
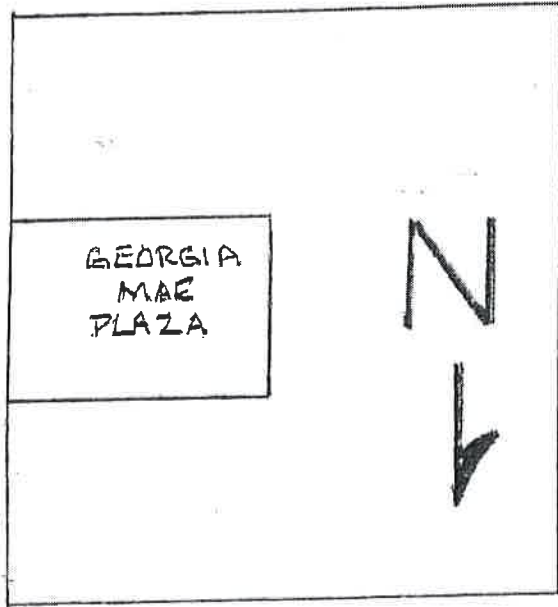
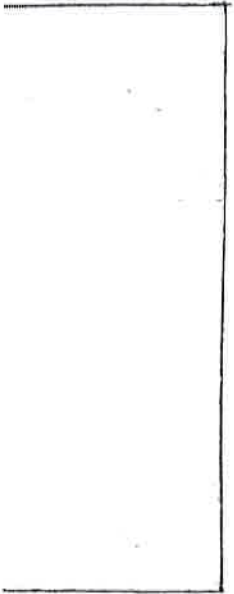

MAIN STREET

FIRST STREET

BONNER STREET

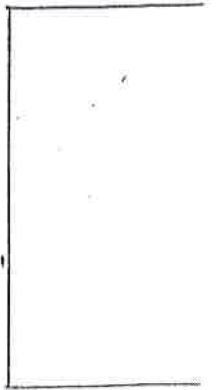
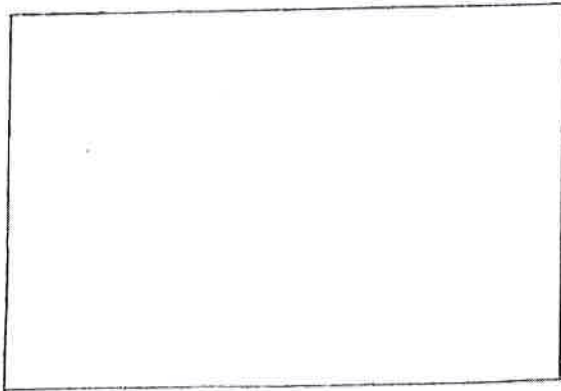
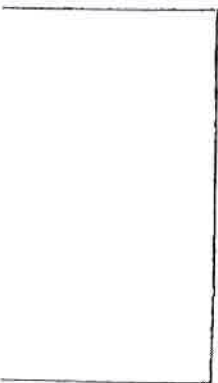

TO FAIRGROUNDS →

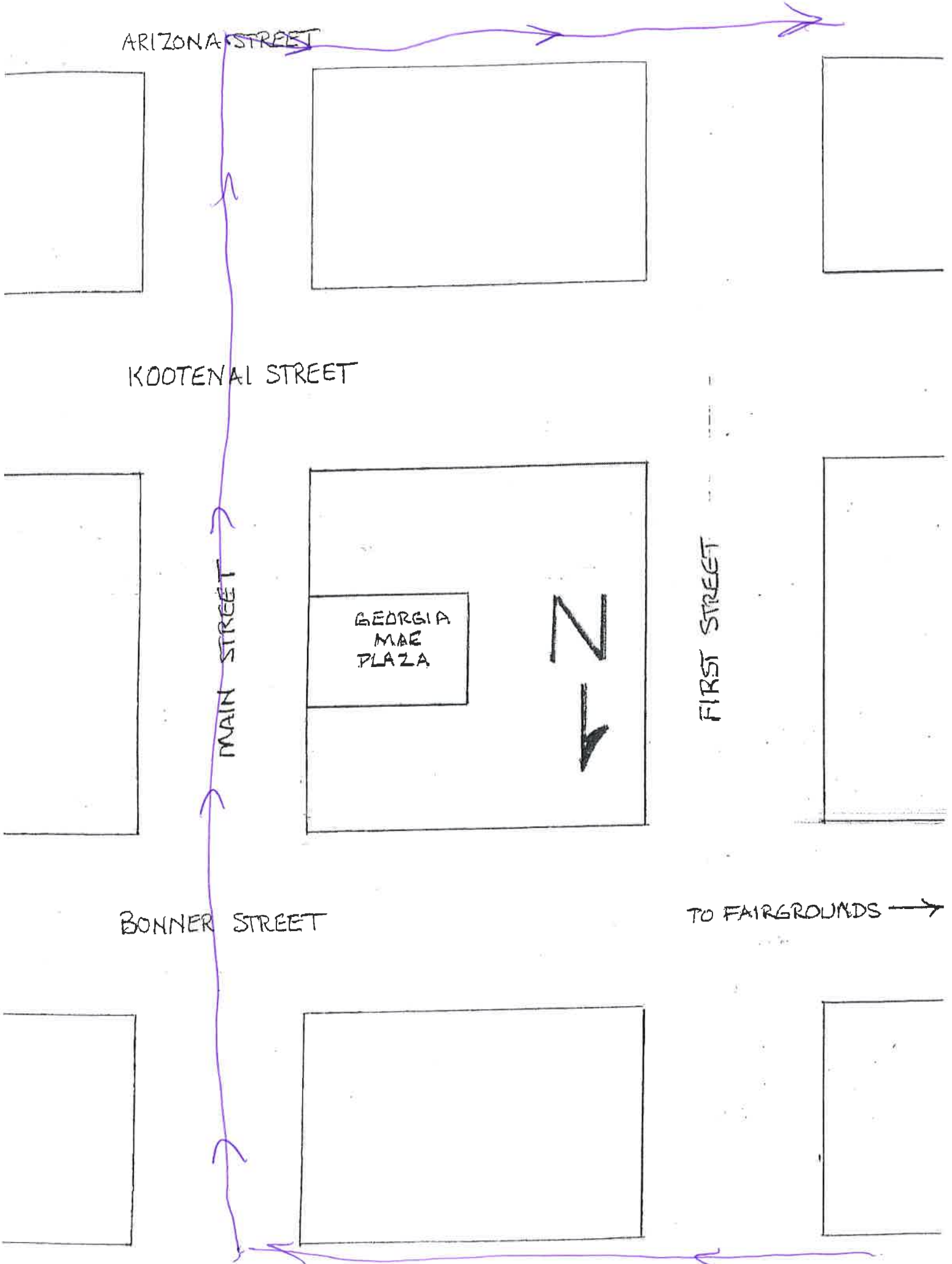



ALMOST HEAVEN RANCH

RECEIVED

MAY 11 2020

CITY OF BONNERS FERRY

City of Bonners Ferry
Attn: Mayor, Dick Staples, and Police Chief, Brian Zimmerman.
PO Box 149
Bonners Ferry, ID 83805

To Whom It May Concern:

One of the things I love most about a close-knot, small town like Bonners Ferry, is that we know many folks at a richer, deeper level. Brian's son was our Son, Lex's classmate. Dezie (spelling?) was Mikkel's classmate. Brian's wife, Roberta, grew up a stone's throw from our Almost Heaven Ranch; Brian and Roberta are now neighbors. Dick's wife, Melanie, goes to church with us, sitting in an adjacent pew, and hosts the Thursday free dinner that so many of our citizens take advantage of the Bonners Ferry, United Methodist Church. And we all recognize that Rockey is the town mascot/crier combo and precious beyond measure.

First of all, thank you both for your service to our community. I know it's not for the money or prestige. Rather, a labor of care, concern and love of the greater good. I feel the same way about Bonners Ferry and Boundary County, our oasis of beauty, goodness and serenity. Speaking of an oasis, where people feel pampered, appreciated, noticed, cared for, catered to and safe, there's a major problem on Comanche Street that needs addressed urgently, strongly, and long-term. Speedy and reckless driving.

Valdie and Rockey (and Jim when he was alive) have complained for years about people driving way too fast and recklessly on Comanche street that runs by their house. Teresa had told me about it for decades (we've been married 42- years) but I really didn't realize the severity of the problem until COVID hit. What's COVID have to do with Comanche Street? It has allowed me to get off of my hamster wheel of constant travel, be home for three months, and repot myself. I've also spent three afternoons a week minimum (4-7 hours each day) working at Valdies home at 6468 Comanche, or Rockey's trailer across the street (behind the Northside School B&B), or picking them up to take them on drives in Boundary County. With 50+ hours actually spent outside there, I've seen SO MANY people driving at speeds up to 55 mph (I've followed some off on Highway 95 pacing them as they veer onto Comanche); looking at mobile phones, teens talking and distracted, some hot rodders, people zooming up from the

"LIFE IN THE SLOW LANE."

THE BECKER FAMILY IS MARTY, TERESA, MIKKEL, LEX & SCOOTER
1175 HIGHWAY ONE HCR 60 BOX 177 BONNERS FERRY IDAHO 83805 USA
PHONE: (208) 267-4444 FAX: (208) 267-4163 E-MAIL: THE BOND @ AOL.COM

hospital/doctor's offices/Restorium or Mark's subdivision to head up the North Hill on 95, or headed downtown. Rockey has great difficulty walking, Valdie has poor vision and walks very slowly with a cane, and I've seen so many vehicles zoom by them with the foot on the gas and not a tap on the brakes. I've seen two near accidents with people entering from the Northside School B&B or leaving the houses that line the side of the road looking out over District 2 and downtown. I've also seen one cat and one dog hit by a speeding car.

The posted speed limit is 20 mph (sign is right out in front of Valdie and Rockey's house), but very, VERY few drivers are compliant. I know it's hard, I even have trouble on some BF streets, because they, like Comanche, are straight shots. Comanche is two straightaways connected by one curve. No stop signs, speed bumps, speed trackers (portable or on a post), or drivers cited for speeding (at least that I've seen) to reduce the clear and present danger.

What I'm asking you to do is as follows:

- 1) Speed limit – Start enforcing it. Maybe do an interview in the BF Herald warning people driving on streets with known speeding problems, that the police will start enforcing the posted limits. Warnings first, then citations, until the lesson sinks in?
- 2) Speed monitors – Does the city have the portable units on trailers that could be rotated around town to show and slow folks until we start to form new driving habits?
- 3) Signage – Maybe post more speed limit signs or signs such as “slow” and/or “Curve Ahead?”

While losing someone like Valdie or Rockey on Comanche would be seismic in our community and sear the serious problem into the hearts, heads and feet of speeders, we can't afford to lose them. What other 95-year-old, beautiful, red-headed lady with a heart of gold do we have? And who's going to compliment the women (“You look beautiful. You're so skinny? Have you lost weight?”) of Boundary County if Rockey ends up flat as a cartoon character crossing the road to eat breakfast/lunch/dinner with his mom? The town mascot CANNOT be taken too early. 😊

Wags,

Marty Becker 5/7/20

Teresa Becker 5/7/20

Marty Becker, DVM
Teresa Becker